



**ARCONIC**  
Innovation, engineered.

**Instruction Manual**  
**256**  
Pneudraulic Installation Tool

*Patent Pending*



<b>Declaration of Conformity</b>	<b>2</b>
<b>Safety Instructions</b>	<b>3</b>
<b>Principle of Operation</b>	<b>4</b>
<b>Tool Specifications</b>	<b>4</b>
<b>Preparation for Use</b>	<b>5</b>
<b>Maintenance</b>	<b>5</b>
<b>Operating Instructions</b>	<b>6</b>
<b>Disassembly Procedure</b>	<b>6-7</b>
<b>Assembly Procedure</b>	<b>8</b>
<b>Fill and Bleed Procedure</b>	<b>9</b>
<b>Components Drawings</b>	<b>10-11</b>
<b>Troubleshooting</b>	<b>14</b>
<b>Accessories</b>	<b>14</b>

August 23, 2017  
**HK1015**

Makers of Huck®, Marson®, Recoil®  
Brand Fasteners, Tools & Accessories



**ARCONIC**

## EC Declaration of Conformity

**Manufacturer:**

Huck International, LLC, Industrial Products Group, 1 Corporate Drive, Kingston, NY, 12401, USA

**Description of Machinery:**

Models 24#, 25#, and 2047 pneudraulic installation tools and specials based on their design (e.g. PR#####).

**Relevant provisions complied with:**

Council Directive related to Machinery (2006/42/EC)

British Standard related to hand held, non-electric power tools (ISO 11148-1:2011)

**European Representative:**

Rob Pattenden, Huck International, Ltd. Unit C Stafford Park 7, Telford Shropshire TF3 3BQ, England, United Kingdom

**Authorized Signature/date:**

I, the undersigned, do hereby declare that the equipment specified above conforms to the above Directive(s) and Standard(s).

Signature: 

Full Name: Robert B. Wilcox

Position: Engineering Manager

Location: Huck International, LLC d/b/a Arconic Fastening Systems and Rings  
Kingston, New York, USA

Date: 01/11/2016 (November 1, 2016)



### Declared dual number noise emission values in accordance with ISO 4871

A weighted sound power level, LWA: **91** dB (reference 1 pW) Uncertainty, KWA: 3 dB

A weighted emission sound pressure level at the work station, LpA: **80** dB (reference 20 µPa) Uncertainty, KpA: 3 dB

C-weighted peak emission sound pressure level, LpC, peak: **115** dB (reference 20 µPa) Uncertainty, KpC: 3 dB

Values determined according to noise test code ISO 3744. The sum of a measured noise emission value and its associated uncertainty represents an upper boundary of the range of values which is likely to occur in measurements.

### Declared vibration emission values in accordance with EN 12096

Measured Vibrations emission value, a:	<b>.63 m/s<sup>2</sup></b>
Uncertainty, K:	<b>.72 m/s<sup>2</sup></b>

Values measured and determined according to ISO 28662-1, ISO 5349-2, and EN 1033

Test data to support the above information is on file at:  
Arconic Fastening Systems and Rings, Kingston Operations, Kingston, NY, USA.





# Safety Instructions

## GLOSSARY OF TERMS AND SYMBOLS:

 Product complies with requirements set forth by the relevant European directives.

 Read manual prior to using this equipment.

 Eye protection is required while using this equipment.

 Hearing protection is required while using this equipment.

Notes: are reminders of required procedures.

***Bold, Italic type, and underline:*** emphasize a specific instruction.

 **WARNINGS: Must be understood to avoid severe personal injury.**

 **CAUTIONS: Show conditions that will damage equipment or structure.**

### I. GENERAL SAFETY RULES:

1. A half hour long hands-on training session with qualified personnel is recommended before using Huck equipment.
2. Huck equipment must be maintained in a safe working condition at all times. Tools and hoses should be inspected at the beginning of each shift/day for damage or wear. Any repair should be done by a qualified repairman trained on Huck procedures.
3. For multiple hazards, read and understand the safety instructions before installing, operating, repairing, maintaining, changing accessories on, or working near the assembly power tool. Failure to do so can result in serious bodily injury.
4. Only qualified and trained operators should install, adjust or use the assembly power tool.
5. Do not modify this assembly power tool. This can reduce effectiveness of safety measures and increase operator risk.
6. Do not discard safety instructions; give them to the operator.
7. Do not use assembly power tool if it has been damaged.
8. Tools shall be inspected periodically to verify all ratings and markings required, and listed in the manual, are legibly marked on the tool. The employer/operator shall contact the manufacturer to obtain replacement marking labels when necessary. Refer to assembly drawing and parts list for replacement.
9. Tool is only to be used as stated in this manual. Any other use is prohibited.
10. Read MSDS Specifications before servicing the tool. MSDS specifications are available from the product manufacturer or your Huck representative.
11. Only genuine Huck parts shall be used for replacements or spares. Use of any other parts can result in tooling damage or personal injury.
12. Never remove any safety guards or pintail deflectors.
13. Never install a fastener in free air. Personal injury from fastener ejecting may occur.
14. Where applicable, always clear spent pintail out of nose assembly before installing the next fastener.
15. Check clearance between trigger and work piece to ensure there is no pinch point when tool is activated. Remote triggers are available for hydraulic tooling if pinch point is unavoidable.
16. Do not abuse tool by dropping or using it as a hammer. Never use hydraulic or air lines as a handle or to bend or pry the tool. Reasonable care of installation tools by operators is an important factor in maintaining tool efficiency, eliminating downtime, and preventing an accident which may cause severe personal injury.
17. Never place hands between nose assembly and work piece. Keep hands clear from front of tool.
18. Tools with ejector rods should never be cycled with out nose assembly installed.
19. When two piece lock bolts are being used always make sure the collar orientation is correct. See fastener data sheet for correct positioning.

### II. PROJECTILE HAZARDS:

1. Risk of whipping compressed air hose if tool is pneudraulic or pneumatic.
2. Disconnect the assembly power tool from energy source when changing inserted tools or accessories.
3. Be aware that failure of the workpiece, accessories, or the inserted tool itself can generate high velocity projectiles.
4. Always wear impact resistant eye protection during tool operation. The grade of protection required should be assessed for each use.
5. The risk of others should also be assessed at this time.
6. Ensure that the workpiece is securely fixed.
7. Check that the means of protection from ejection of fastener or pintail is in place and operative.

8. There is possibility of forcible ejection of pintails or spent mandrels from front of tool.

### III. OPERATING HAZARDS:

1. Use of tool can expose the operator's hands to hazards including: crushing, impacts, cuts, abrasions and heat. Wear suitable gloves to protect hands.
2. Operators and maintenance personnel shall be physically able to handle the bulk, weight and power of the tool.
3. Hold the tool correctly and be ready to counteract normal or sudden movements with both hands available.
4. Maintain a balanced body position and secure footing.
5. Release trigger or stop start device in case of interruption of energy supply.
6. Use only fluids and lubricants recommended by the manufacturer.
7. Avoid unsuitable postures, as it is likely for these not to allow counteracting of normal or unexpected tool movement.
8. If the assembly power tool is fixed to a suspension device, make sure that fixation is secure.
9. Beware of the risk of crushing or pinching if nose equipment is not fitted.

### IV. REPETITIVE MOTION HAZARDS:

1. When using assembly power tool, the operator can experience discomfort in the hands, arms, shoulders, neck or other parts of the body.
2. When using tool, the operator should adopt a comfortable posture while maintaining a secure footing and avoid awkward or off balanced postures.
3. The operator should change posture during extended tasks to help avoid discomfort and fatigue.
4. If the operator experiences symptoms such as persistent or recurring discomfort, pain, throbbing, aching, tingling, numbness, burning sensations or stiffness, these warnings should not be ignored. The operator should tell the employer and consult a qualified health professional.

### V. ACCESSORIES HAZARDS:

1. Disconnect tool from energy supply before changing inserted tool or accessory.
2. Use only sizes and types of accessories and consumables that are recommended. Do not use other types or sizes of accessories or consumables.

### VI. WORKPLACE HAZARDS:

1. Be aware of slippery surfaces caused by use of the tool and of trip hazards caused by the air line or hydraulic hose.
2. Proceed with caution while in unfamiliar surroundings; there could be hidden hazards such as electricity or other utility lines.
3. The assembly power tool is not intended for use in potentially explosive environments.
4. Tool is not insulated against contact with electrical power.
5. Ensure there are no electrical cables, gas pipes, etc., which can cause a hazard if damaged by use of the tool.

### VII. NOISE HAZARDS:

1. Exposure to high noise levels can cause permanent, disabling hearing loss and other problems such as tinnitus, therefore risk assessment and the implementation of proper controls is essential.
2. Appropriate controls to reduce the risk may include actions such as damping materials to prevent workpiece from 'ringing'.
3. Use hearing protection in accordance with employer's instructions and as required by occupational health and safety regulations.
4. Operate and maintain tool as recommended in the instruction handbook to prevent an unnecessary increase in the noise level.
5. Select, maintain and replace the consumable / inserted tool as recommended to prevent an unnecessary increase in noise.
6. If the power tool has a silencer, always ensure that it is in place and in good working order when the tool is being operated.

### VIII. VIBRATION HAZARDS:

1. Exposure to vibration can cause disabling damage to the nerves and blood supply to the hands and arms.
2. Wear warm clothing when working in cold conditions and keep hands warm and dry.
3. If numbness, tingling, pain or whitening of the skin in the fingers or hands, stop using the tool, tell your employer and consult a physician.
4. Support the weight of the tool in a stand, tensioner or balancer in order to have a lighter grip on the tool.

### IX. PNEUMATIC / PNEUDRAULIC TOOL SAFETY INSTRUCTIONS:

1. Air under pressure can cause severe injury.
2. Always shut off air supply, drain hose of air pressure and disconnect tool from air supply when not in use, before changing accessories or when making repairs.
3. Never direct air at yourself or anyone else.
4. Whipping hoses can cause severe injury, always check for damaged or loose hoses and fittings.
5. Cold air should be directed away from hands.
6. Whenever universal twist couplings (claw couplings) are used, lock pins shall be installed and whip-check safety cables shall be used to safeguard against possible hose to hose or hose to tool connection failure.
7. Do not exceed maximum air pressure stated on tool.
8. Never carry an air tool by the hose.





## Principle of Operation

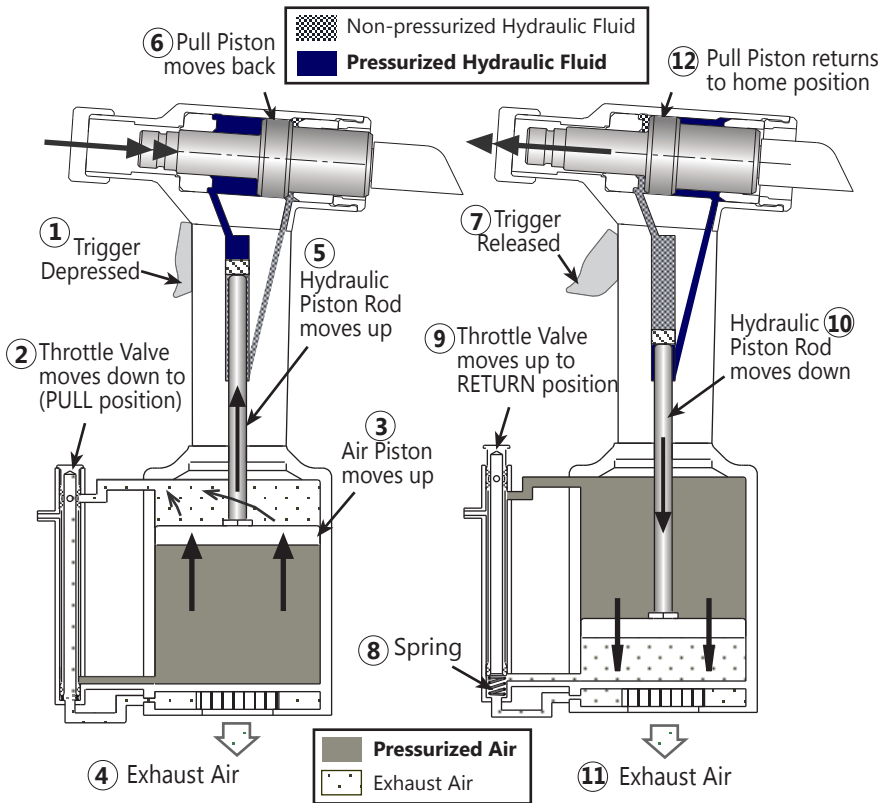

When the Trigger is depressed (1), the Throttle Valve moves to the down position (2), and pressurized air is directed to the bottom of the Air Piston, causing it to move upward (3). The air above the Piston is exhausted and directed through the center of the Throttle Valve and out the bottom of the tool (4). The Air Piston has a Rod and a Hydraulic Piston attached. When the Air Piston rod moves upward, a column of pressurized hydraulic fluid is forced up (5) into the tool head, which moves the Pull Piston back (6). The attached nose assembly moves with the Pull Piston to start fastener installation. When fastener installation is completed, the Trigger is released (7). Air pressure, with the assistance of a Spring (8), causes the Throttle Valve to return to its up position (9). Pressurized air is re-directed to the top of the Air Piston, causing it, along with the Hydraulic Piston Rod, to move downward (10). The air from below the Air Piston is exhausted through the bottom of the tool (11). As this occurs, hydraulic pressure is reversed and the Pull Piston is returned forward (12). A return pressure relief valve protects the tool against pressure spikes. The reservoir replenishes the hydraulic system as needed.

## Specifications

### POWER SOURCE:

110 psi MAX shop air

### HOSE KITS:

Use only genuine HUCK Hose Kits rated @ 10,000 psi working pressure.

### HYDRAULIC FLUID:

Hydraulic fluid shall meet DEXRON® III, DEXRON VI, MERCON, Allison C-4 or equivalent ATF specifications. Fire resistant fluid may be used if it is an ester based fluid such as Quintolubric HFD or equivalent. Water based fluid shall NOT be used as serious damage to equipment will occur.

**WEIGHT:** 11.1 lbs (5.03 kg)

### MAX OPERATING TEMP:

125°F (51.7°C)

**SPEED/CYCLES:** 30 per minute

### MAX FLOW RATE:

22.4 scfm (634 l/m)

### MIN PULL CAPACITY:

9986 lbs (44.42 kN) @ 90 psi

### MAX INLET PRESSURE:

110 psi (6.2 bar)

### MIN STROKE:

.875 inches (2.22 cm)

.750 inches (1.91 cm) when used with Stroke Limiter 118362-1

### Where the following trade names are used in this manual, please note:

**DEXRON** is a registered trademark of General Motors Corporation.

**Loctite** is a registered trademark of Henkel Corporation, U.S.A.

**LUBRIPLATE** is a registered trademark of Fiske Brothers Refining Co.

**MERCON** is a registered trademark of Ford Motor Corp.

**Never-Seez** is a registered trademark of Bostik, Inc.

**Quintolubric** is a registered trademark of Quaker Chemical Corp.

**Slic-tite** is a registered trademark of LA-CO Industries, Inc.

**Spirolox** is a registered trademark of Smalley Steel Ring Company

**Teflon** is a registered trademark of E. I. du Pont de Nemours and Company.

**Threadmate** is a registered trademark of Parker Intangibles LLC.

**TRUARC** is a trademark of TRUARC Co. LLC.

**Vibra-Tite** is a registered trademark of ND Industries, Inc. USA.

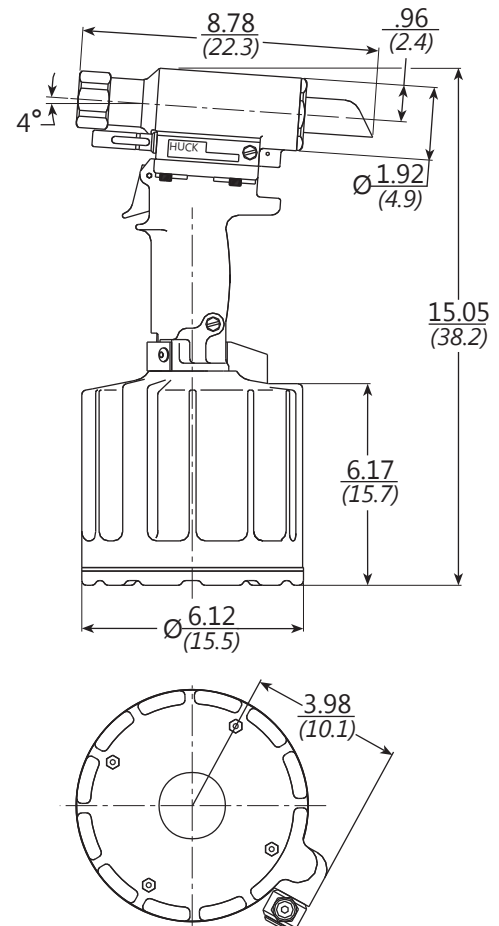



## Preparation for Use

The Model 256 Installation Tool is shipped with a plastic plug in the air inlet connector. The connector has 1/4-18 female pipe threads to accept the air hose fitting. Quick disconnect fittings and 1/4" inside diameter air hose are recommended. An air supply of 90-100 psi capable of 22.4 CFM must be available. Air supply should be equipped with a filter-regulator-lubricator unit.

1. Remove plastic shipping plug from air inlet connector and put in a few drops of Automatic Transmission Fluid, DEXRON III, or equivalent.
2. Apply TEFLON in stick form to threads of Air Hose, and screw hose into the tool.



**Caution:** Do not use TEFLON tape on threads. Use only in stick form: Huck P/N 503237.

3. Set air pressure on regulator to 90-100 psi.
4. Screw air fitting (not supplied with tool) into Air Hose and connect to air source. Quick disconnect fitting into Air Inlet Connector, or screw quick disconnect fitting into Air Inlet Connector, then attach optional Air Hose supplied with tool.

5. Cycle tool a few times by depressing and releasing trigger.
6. Disconnect air hose from tool.
7. Remove retaining nut and stop.
8. Select proper nose assembly for fastener to be installed.
9. Screw collet assembly, including lock collar and shim, if applicable, onto spindle holding Hydraulic Pull Piston of tool with 3/8 hex key. Wrench tight.
10. Slide nose assembly anvil over collet assembly and into counterbore.
11. Slide tool's Stop and Retaining Nut over nose assembly anvil and screw Nut onto tool head.
12. Connect air hose to tool and install fastener(s) in a test plate of proper thickness with proper size holes. Inspect fastener(s).

*NOTE: Threadmate® should be used on collet threads for nose assemblies without lock collars. All other noses should be staked.*

## Maintenance



**WARNING:** Inspect tool for damage or wear before each use. Do not operate if damaged or worn, as severe personal injury may occur.

**NOTE: WARNING Sticker and HUCK Trademark Sticker must be in place and readable at all times.**

### GENERAL

1. The efficiency and life of any tool depends upon proper maintenance. Regular inspection and correction of minor problems will keep tool operating efficiently and prevent downtime. The tool should be serviced by personnel who are thoroughly familiar with how it operates.
2. A clean, well-lighted area should be available for servicing the tool. Special care must be taken to prevent contamination of pneumatic and hydraulic systems.
3. Proper hand tools, both standard and special, must be available.
4. All parts must be handled carefully and examined for damage or wear. Always replace Seals, when tool is disassembled for any reason. Components should be disassembled and assembled in a straight line without bending, cocking, or undue force. Disassembly and assembly procedures outlined in this manual should be followed.
5. Service Parts Kit 256KIT includes consumable parts and should be available at all times. Other components, as experience dictates, should also be available.

### DAILY

1. If a Filter-Regulator-Lubricator unit is not being used, uncouple air disconnects and put a few drops of Automatic Transmission Fluid or light oil into the air inlet of the tool. If the tool is in continuous use, put a few drops of oil in every two to three hours.
2. Bleed the air line to clear it of accumulated dirt or water before connecting air hose to the tool.
3. Check all hoses and couplings for damage or air leaks, tighten or replace if necessary.
4. Check the tool for damage or air/hydraulic leaks, tighten or replace if necessary.
5. Check the nose assembly for tightness or damage, tighten or replace if necessary.
6. Check oil level in tool reservoir, replenish if necessary.

### WEEKLY

1. Disassemble and clean nose assemblies and reassemble.
2. Check the tool and all connecting parts for damage or oil/air leaks, tighten or replace if necessary.



## Operating Instructions

Failure to understand **WARNINGS** may cause serious personal injury. Failure to understand **CAUTIONS** may cause damage to structure and Tool. For additional Safety Information, see page 4.

### LOCKBOLT® FASTENER INSTALLATION:



**WARNING:** Do not pull a fastener without a collar. The fastener will eject with velocity and force when the pintail breaks off. This may cause serious injury.



**CAUTION:** Remove excess gap from between the sheets. This permits enough pintail to emerge from collar for ALL jaw teeth to engage with pintail. If ALL teeth do not engage properly, jaws will be stripped/damaged.

Place pin in work hole and place collar over pin. See WARNING. (If Collar has only one tapered end, that end must be facing toward tool, not next to workpiece.) Hold pin and push nose assembly onto pin protruding through collar until nose assembly anvil touches collar. Press trigger and hold pressed until collar is swaged and pintail breaks. Release trigger and tool will go into return stroke. The tool and nose assembly are ready for the next fastener installation cycle.

### BLIND FASTENER INSTALLATION:



**WARNING:** Do not pull a fastener without a collar. The fastener will eject with velocity and force when the pintail breaks off. This may cause serious injury.



**CAUTION:** To avoid structural and Tool damage, be sure enough clearance is allowed for nose assembly at full stroke. Do not abuse the tool by dropping it, using it as a hammer or otherwise causing unnecessary wear and tear. Reasonable care of installation tools by operators is an Important factor in maintaining tool efficiency and reducing downtime.

Remove excess gap from between the sheets to permit correct fastener installation. Tool and nose assembly must be held against workpiece, and at a right angle to it. Press trigger and hold it pressed until fastener is installed and pintail breaks. Release trigger and tool will go into its return stroke. The tool and nose assembly are ready for next fastener installation cycle.

## Disassembly Procedure



**WARNING:** Be sure air hose is disconnected from tool before cleaning or performing maintenance. Severe personal injury may occur if air hose is not disconnected.



**CAUTION:** Do not scratch piston rod or cylinder during removal. Use a plastic or wooden drift to avoid damaging handle bore.

**NOTE:** Disassemble only those components necessary to replace damaged O-rings, Quad rings, Back-up rings, and worn or damaged components. Always use soft-jaw vice to avoid damage to tool.

1. Disconnect air hose from tool and remove nose assembly.
3. (Figure 1) Insert Fill Tool through reservoir housing and screw into Reservoir Plunger, locking it in the out position.
4. Unscrew 4 Cap Screws with 5/32 hex key. Carefully lift Tool Head straight up from Handle, and remove Pull and Return Gland Assemblies. Remove seals from glands.
5. Unscrew Relief Valve Plug from front of head. Remove Relief Valve Spring, Guide, Sleeve, and Ball. Using a small magnet is helpful.
6. Unscrew Reservoir Fill Plug. Hold over waste oil container and release fill tool slowly.
7. Unscrew Reservoir Housing from head. Remove 2 Springs. Slide Reservoir Plunger from head. Remove spacer and Quad Ring. A pick may be used to remove the Quad Ring.

Figure 1

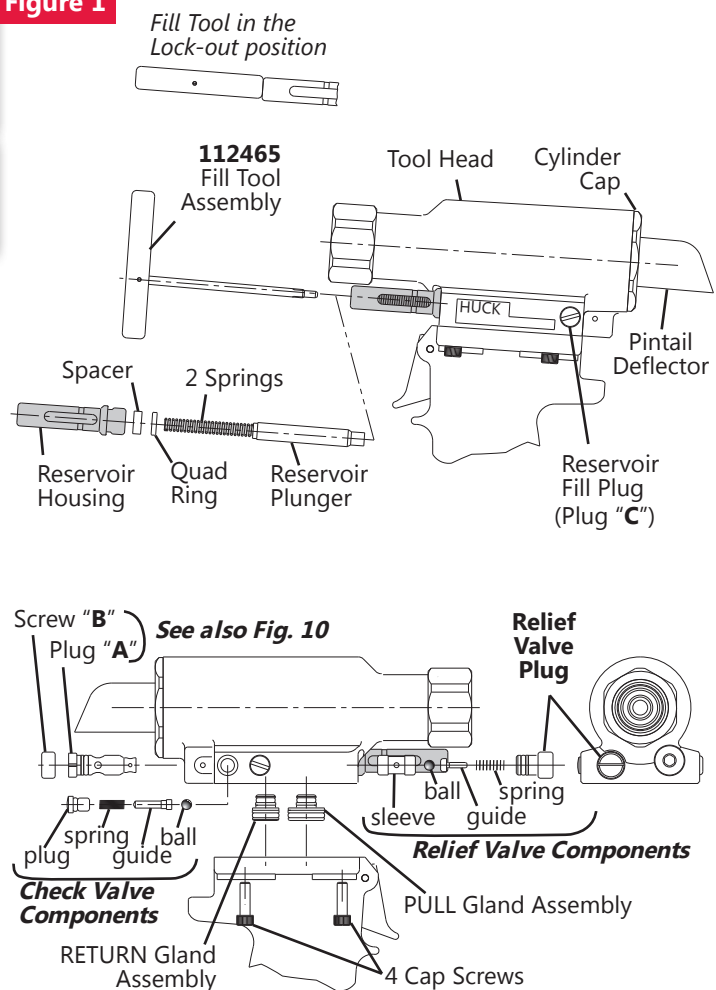



## Disassembly Procedure continued

8. Unscrew Check Valve Plug from side of head. Remove Check Valve Spring, Guide, and Ball. A small magnet is helpful.
9. If Check Valve Seat (Figure 10) is damaged, contact your HUCK representative. If Relief Valve Seat is damaged, it can be removed as described in step 10. **NOTE:** If seats are removed, they may not be reused; they must be replaced.
10. **RELIEF VALVE SEAT ASSEMBLY REMOVAL Note:** All parts in check valve hole must be removed before Plug "A" can be removed. (Figs. 1 & 10) Unscrew Screw "B". Insert a #10 screw in the thread of Plug "A", and pull to remove. Using a small drift and hammer, from rear side of head, drive Relief Valve Seat Assy (Fig. 10) out toward the front of the head.
11. Pintail Deflector can be pulled off barbed end at rear of Hydraulic Pull Piston.
12. Unscrew Cylinder Cap from Cylinder/Head using a 1-3/4" open-end wrench.
13. (Fig. 2) Place Spacer on Hydraulic Pull Piston, and screw Assembly/Disassembly Bullet onto piston. Tap or press piston assembly out of head. **This will push out front and rear gland assemblies and wiper and wiper housing.**
21. Push Air Piston all the way into cylinder and lay tool on its side. Hold Self-locking Nut with a 9/16 socket and extension and, with 7/64 hex key, unscrew Intensifier Piston Screw.
22. Turn cylinder and handle upside down and secure in a vise.
23. Grip Self-locking Nut under Air Piston with pliers and pull piston and rod assembly from handle and cylinder assembly.
24. With a 1 3/8 socket and extension, remove Main Gland Assembly. Handle and cylinder will now separate.
25. To remove Polyseal from Gland Assembly, remove the Gland Assembly Retaining Ring and Spacer first.
26. Using a soft drift, push Intensifier Piston out of handle.
27. To service handle sleeve and handle, use a blunt-tipped punch to gently tap sleeve from top of handle through the bottom. Inspect sleeve for damage or wear, and replace if necessary. Service O-ring inside handle bore.

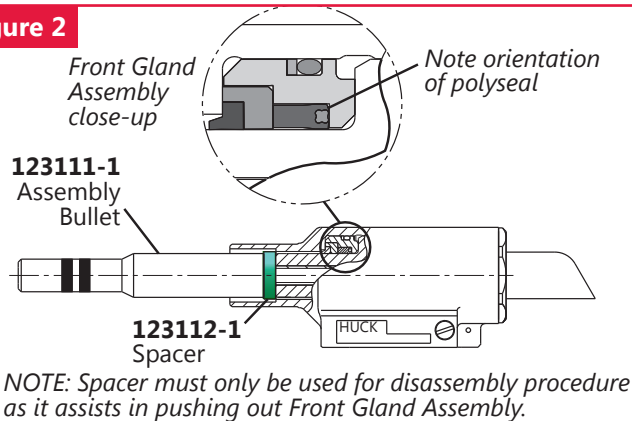
**Figure 2**

- 14.(Fig. 11) Remove Throttle Arm Screw; then remove Throttle Arm. Pull Throttle Valve out of cylinder, and remove Spring.
- 15.(Fig. 10) With a small punch and hammer, drive Trigger Pin from the Handle. Remove Cable Pin. Remove ball end of Cable from Throttle Arm (Fig. 11), and pull cable out of handle.
16. Remove Reservoir Fill Plug from handle. (Fig. 10)
17. (Fig. 3) Hold tool inverted in vice. Unscrew 3 Cap Screws with 5/32 hex key.
18. Remove Muffler End Cap, Bottom Exhaust Gasket, Muffler and O-ring.
19. Remove Retaining Ring from Cylinder Assembly. **Tap Cylinder Head down into Cylinder Assembly for easier removal of Retaining Ring.**
20. Screw Cap Screws into Cylinder Head, and carefully pry under screws to remove Cylinder Head. (Figure 3)

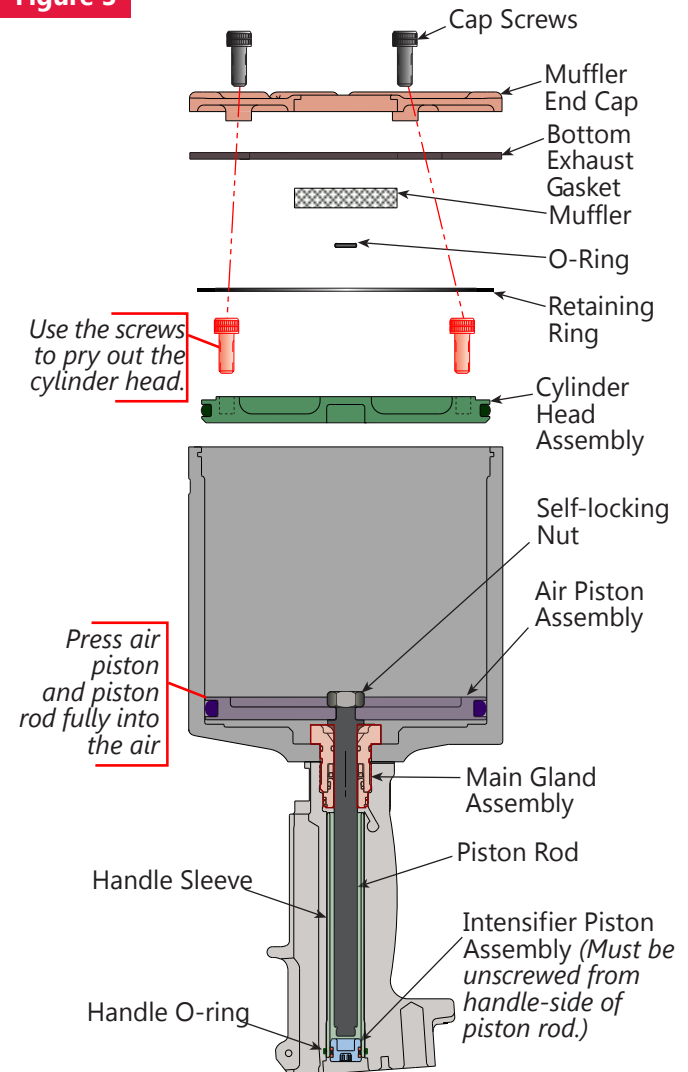
**Figure 3**





## Assembly

Clean components with mineral spirits or similar solvent. Inspect for wear/damage and replace as necessary. Replace all seals of disassembled components using Service Parts Kit, P/N 256KIT. Smear LUBRIPLATE 130AA or PARKER-O-LUBE on rings and mating parts to ease assembly. Carefully assemble tool without damaging O-rings, Quad rings, or Back-up rings.

**Figure 4**

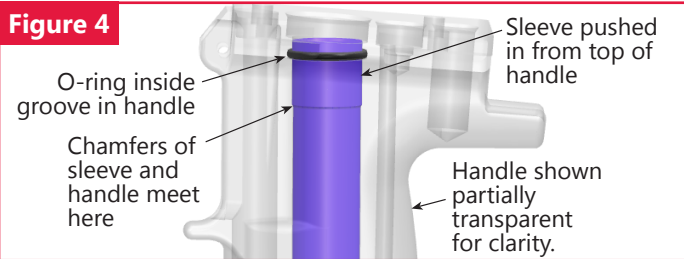

**Figure 5**

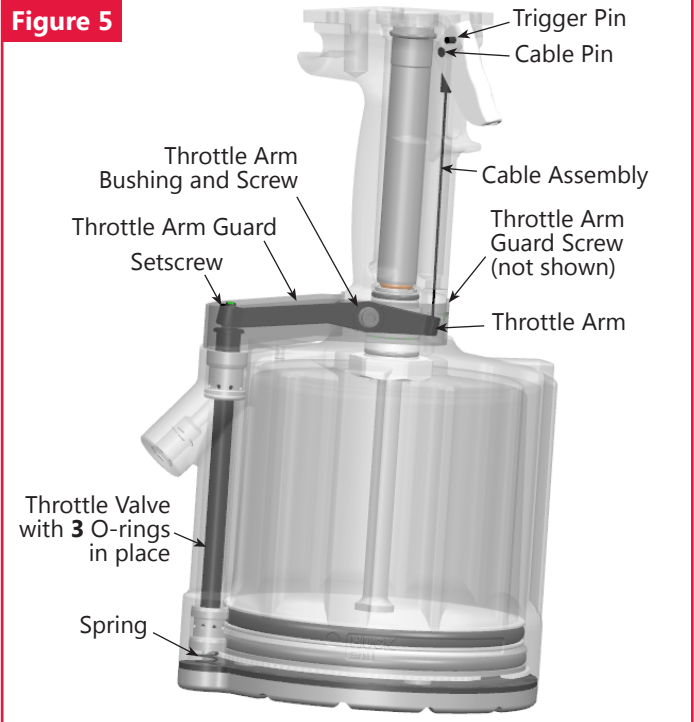

"A", with seals in place, into head. Install Screw "B". (Figure 10)

1. (Figure 4) Install O-ring inside handle; then push sleeve in handle until it bottoms on the chamfer.
2. Holding handle inverted in a vice, install timing pin; then place air cylinder on handle with timing pin positioned in matching hole. Assemble Main Gland Assembly. Apply anti-seize compound (p/n 508183) to gland threads. With a 1-3/8 inch socket wrench, torque it into the handle to 75-85 foot lbs.
3. Push air piston assembly and piston rod into air cylinder until it seated inside of air cylinder (Figure 3).
4. Turn tool upright. Assemble Intensifier Piston with O-Ring and Back-up Rings; then apply Loctite 243 to intensifier piston screw threads, and carefully press in from top of handle.
5. Holding Self-locking Nut with 9/16 socket and extension, screw intensifier piston onto piston rod using 7/64 hex key, and torque to 180-190 in. lbs.
6. Hold handle in vise with bottom up. Push Cylinder Head Assembly squarely into air cylinder. Install Retaining Ring.
7. Position O-Ring and Muffler on center of air cylinder. Place Bottom Exhaust Gasket on air cylinder. Place Muffler End Cap on top of Gasket, and secure with 3 Cap Screws using 5/32 hex key.
8. Turn tool upright. (Figure 5) Drop Throttle Valve Spring into Throttle Valve hole in cylinder. Push Throttle Valve, with O-rings in place, into cylinder.
9. Assemble Trigger, Cable, and Cable Pin, and slide Cable into Handle. Align hole in Trigger with hole in Handle and install Trigger Pin with a hammer and punch.
10. Slide Throttle Arm onto ball end of throttle cable. Swing arm until end fits over throttle valve. Attach throttle arm Bushing and Screw to Throttle Arm. Tighten with 5/32 hex key.
11. If air hose assembly was removed, reinstall it.
12. If Relief Valve Seat Assy is being replaced, push Plug
13. Carefully drive Relief Valve Seat Assy in using a soft drift, without damaging Relief Valve Ball surface.
14. Assemble Pull Piston with new seals. Lubricate with LUBRIPLATE or PARKER SUPER-O-LUBE.
15. Thread Assembly Bullet onto Pull Piston Assy. (Figure 2) **NOTE:** Spacer not needed during assembly. Its purpose is to push out the front gland during disassembly.
16. Push Front Gland Assy, with all seals, Housing, and Wiper in place, over Assembly Bullet and onto Pull Piston. Push entire gland/piston assembly into Head.
17. (Figure 10) Install O-rings and Back-up Rings on Rear Gland and push complete assembly into Head. Screw in Cylinder Cap and tighten.
18. (Figure 10) Install O-ring & Back-up Ring on Relief Valve Plug; then install Ball, Guide, Sleeve, Spring, and assembled Relief Valve Plug into head.
19. Install O-ring on Check Valve Plug "D", then install Ball, Guide, Spring, and assembled Check Valve Plug into head.
20. Push Pintail Deflector onto barbed end of Pull Piston.
21. (Figure 10) Place O-rings on Bleed Plugs "C" & "E" and screw assemblies into Handle and Cylinder Head.
22. (Figure 10) Install all O-rings and Back-up Rings on Pull and Return Glands. Push Gland Assemblies into handle. Push Head down on glands.
23. Place tool in a vise, head down, and install 4 Cap Screws, and proceed to Fill & Bleed section of this manual.





## Fill and Bleed

### Equipment Required:

- Shop airline 90-100 psi max.
- Air regulator
- Fill Bottle (Fig. 7, supplied with tool)
- Fill Tool 112465
- Large flat blade screwdriver
- Stall Nut 120824
- Nose assembly
- Fasteners (Optional)

### Preparation:

1. Install air regulator in airline, and set pressure to 20-40 psi.
2. Fill bottle almost full of DEXRON III - ATF (automatic transmission fluid). **NOTE: Refill tool only when red line on plunger drops below the red line on the reservoir housing or when tool is rebuilt.**

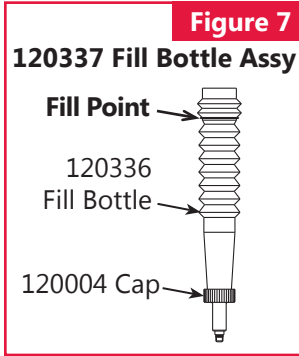

Figure 7

### 120337 Fill Bottle Assy

**STEP 4:** Attach the tool air source momentarily to seat Air Piston at bottom of Air Cylinder, then disconnect tool. **With Reservoir Fill port facing up, lay tool on its side.**

**STEP 5:** Install Fill Bottle in Reservoir Fill port. (Figure 9)

**STEP 6:** Connect tool to shop air 20 to 40 psi. Cycle tool 20-30 times, watch for air bubbles escaping from the tool into bottle. (You may rock the tool to free trapped air in the tool.) Do not allow the air to re-enter the tool. When cycling tool, always hold bottle up as shown in Figure 10 to prevent drawing in air from empty part of bottle.

**STEP 7:** When air bubbles no longer appear in bottle, remove Fill

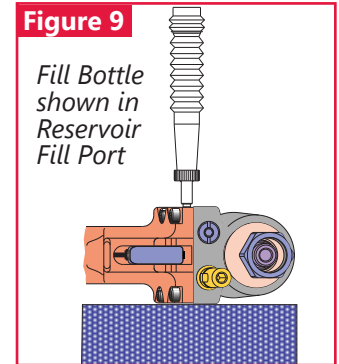

Figure 9

Fill Bottle shown in Reservoir Fill Port



**WARNING: Avoid contact with hydraulic fluid. Hydraulic fluid must be disposed of in accordance with Federal, State and Local Regulations.**



**WARNING: Air pressure MUST be set to 20 to 40 psi to prevent possible injury from high pressure spray. If Check Valve Plug is removed, Fill Bottle must be in place before cycling tool.**

FOR PARTS IDENTIFICATION, SEE FIGURES 10 AND 11.

**STEP 1:** Screw Fill Tool into Reservoir Plunger, pull Plunger into Reservoir Housing and lock Fill Tool in full forward position by

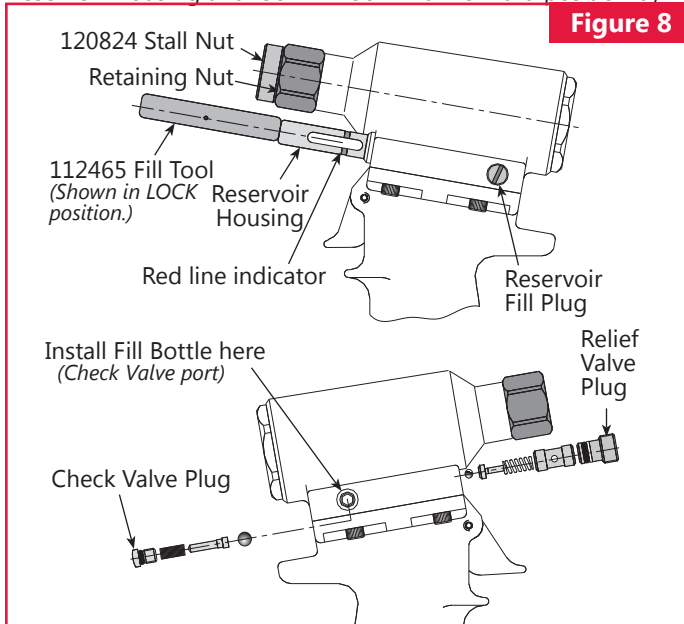

Figure 8

tilting handle (long side touching tool) and locking in place. (Figure 8)

**STEP 2:** Remove Relief and Check Valve Plugs, Guides, Springs and Balls from ports in head. Reinstall Plug and Sleeve in head in Relief Valve port (front of tool).

**STEP 3:** Screw retaining nut onto Head Assembly. Screw Stall Nut onto Hydraulic Piston and tighten to ensure full thread engagement. Back off Retaining Nut until it engages Stall Nut. Check that Hydraulic Piston is all the way forward and locked with Retaining Nut and with (or without) Stall Nut.

**STEP 8:** Install the Check Valve Ball, Guide and Spring. Replace the Check Valve Plug.

**STEP 9:** Turn tool so front of head faces you. Prior to removing Relief Valve Plug, using a 3/32 Allen wrench, back out setscrew inside of the plug approximately 1/2 turn counterclockwise. This ensures that the Piston will remain in full-forward position. Remove the Relief Valve Plug, install Ball, Guide, Sleeve and Spring, and replace the plug.

**STEP 10:** Unlock Fill Tool and check Reservoir red line. Cycle the tool the with Stall Nut attached and Retaining Nut locked in the full-forward position ("Dead Stall"). Reservoir should not drop below the red line on the Reservoir housing.

**STEP 11:** Re-lock the fill tool. Lay tool on its side and remove Reservoir Fill Plug. Top off Reservoir by placing a few drops of oil in hole and waiting for air bubbles to escape. Push a pin or a scribe into hole to check for trapped air bubbles. Replace Plug.

**STEP 12:** Unlock the Fill Tool and cycle tool as in step 10. Reservoir may drop slightly. If so, repeat step 11 until, when the



**WARNING: Failure to re-lock Fill Tool will result in oil being ejected from the head under pressure during the topping off of the Reservoir. Severe personal injury may result.**

Fill Tool handle is touched, it has no pressure against it and it drops out of the lock position, and the Reservoir Plunger does not drop when tool is cycled. NOTE: This usually requires 3 to 4 times topping off.

**STEP 13:** Remove Fill Tool and Stall Nut. Install a nose assembly and pull several fasteners to test function.



# Head/Handle Components

Figure 10

**\*NOTE: Stickers must remain on tool and readable at all times. If stickers become worn, damaged, or if they are missing, they must be ordered and replaced.**

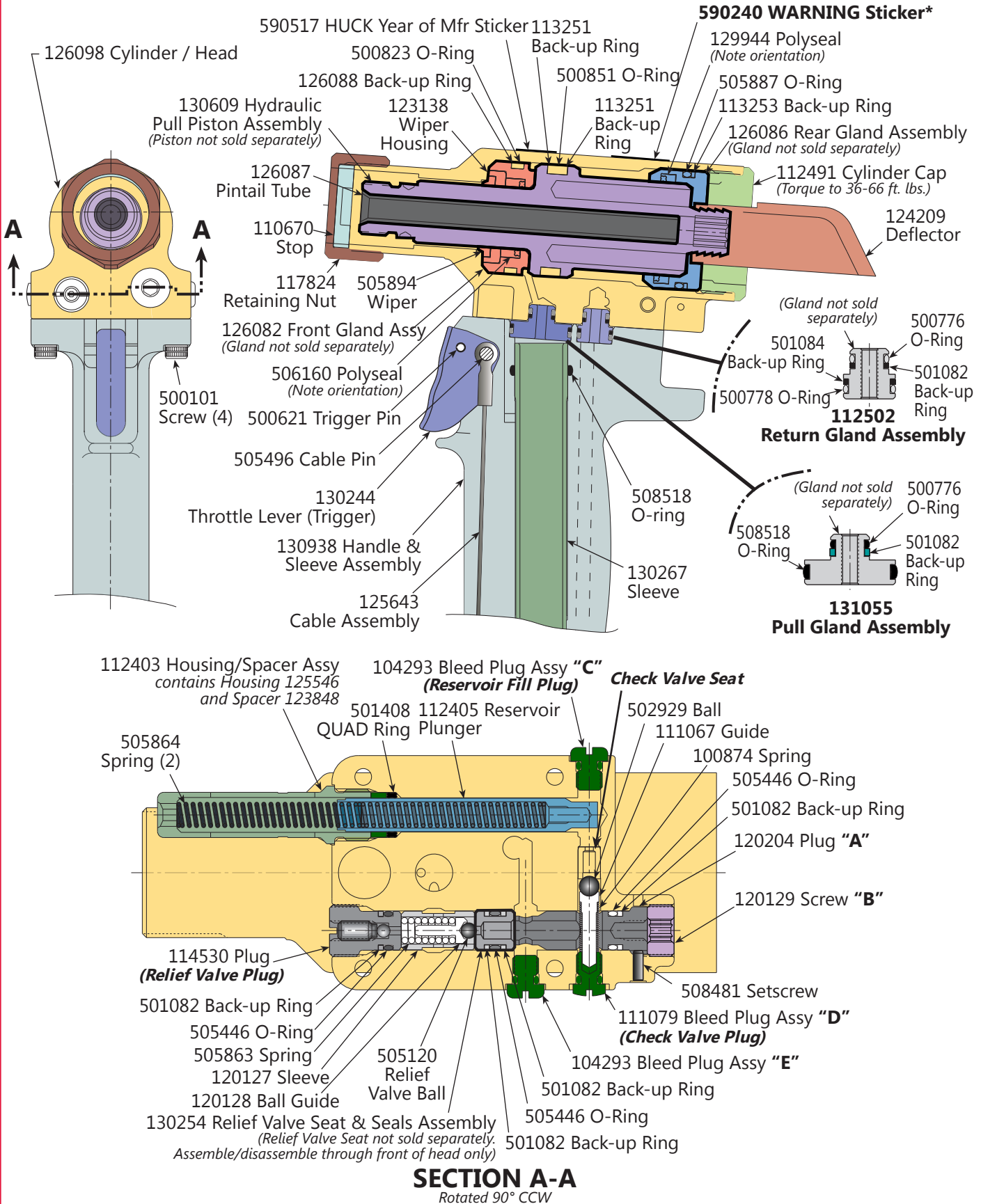



# Air Cylinder Components

Figure 11

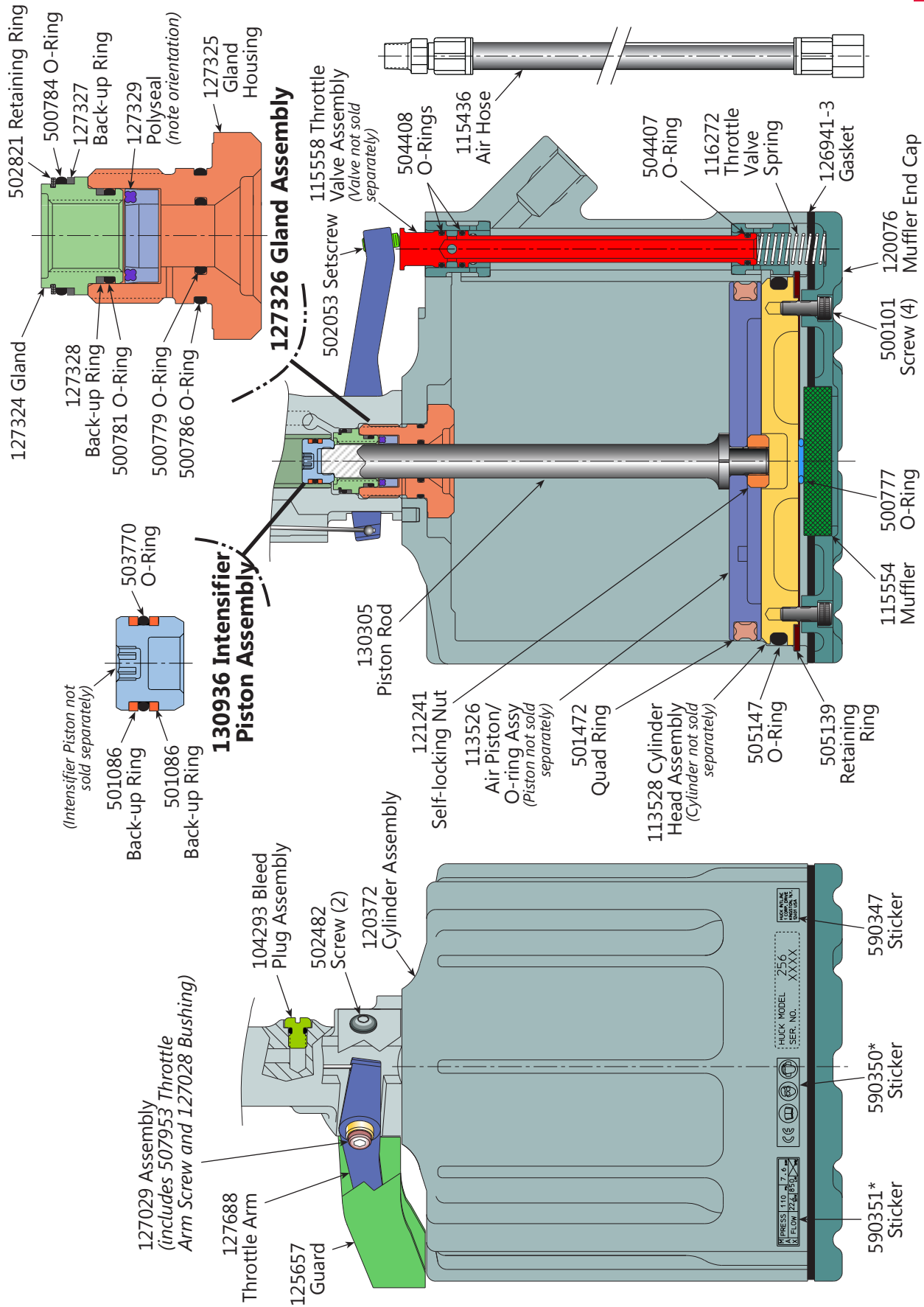



## Accessories

Stroke Limiter	-	118362-1
Reduces stroke to .750 inches (1.91 cm)		
Stall Nut	-	120824
Pintail Collection Bag	-	125655

Service Tool Kit	-	126104
Includes:		
Piston Assembly Bullet (Fig. 2)	-	123111-1
Spacer (Fig. 2)	-	123112-1

## Troubleshooting

Always check out the simplest possible cause of a malfunction first. For example, an air hose not connected. Then proceed logically, eliminating each possible cause until the cause is located. Where possible, substitute known good parts for suspected bad parts. Use this section as an aid in locating and correcting malfunction.

**Note:** "Piston drift" is when the air piston is in the down position, but the hydraulic pull piston is not in the full forward position. This causes an out of sequence condition.

- 1 Tool fails to operate when trigger is depressed:
  - a) Air line not connected
  - b) Throttle Valve O-rings worn or damaged.
  - c) Throttle Valve Cable is broken.
- 2 Tool does not complete fastener installation and break pintail:
  - a) Air pressure too low
  - b) Air Piston Quad Ring worn or damaged.
  - c) Reservoir empty or low, refer to Fill and Bleed section.
  - d) Air in hydraulic system, refer to Fill and Bleed section.
  - e) Reservoir Springs worn or damaged
  - f) Check for piston drift
- 3 Pintail stripped and/or swaged collar not ejected:
  - a) Check for broken or worn jaws in nose assembly, refer to nose assembly data sheet.
  - b) Check for loose Retaining Nut
  - c) Check for piston drift.
- 4 Tool has piston drift:
  - a) Loose collet crashing into the front of the anvil causes the relief valve to open allowing the piston to drift. Tighten the collet and refer to Fill and Bleed section.
  - b) Worn or damaged Return Pressure Relief Valve in tool, inspect Seat, O-ring, Back-up Rings, Steel Ball and Valve Spring. Replace if necessary.
  - c) Worn or damaged Intensifier Piston Assembly: Inspect O-rings and Back-up Rings, and replace if necessary.
- 5 Hydraulic fluid exhausts with air or leaks at base of handle.
  - a) Worn or damaged Gland Assembly: Inspect Polyseal, O-rings, Quad Ring, and Back-up Ring, and replace if necessary.
6. Hydraulic fluid leaks at rear of Pull Piston
  - a) Worn or damaged Rear Gland: Inspect O-rings and Back-up Rings, and replace if necessary.
7. Hydraulic fluid leaks at front of Pull Piston.
  - a) Worn or damaged Front Gland: Inspect Polyseal and replace if necessary.
8. Pull Piston will not return.
  - a) Throttle Valve stuck: Lubricate O-Rings.
  - b) Throttle Arm, Cable, or Trigger binding.
9. Air leaks at Air Cylinder Head.
  - a) Worn or damaged O-Ring. Replace if necessary.





## Limited Warranties

### Limited Lifetime Warranty on BobTail® Tools:

Huck International, Inc. warrants to the original purchaser that its BobTail® installation tools manufactured after 12/1/2016 shall be free from defects in materials and workmanship for its **useful lifetime**. This warranty does not cover special order / non-standard products, or part failure due to normal wear, tool abuse or misapplication, or user non-compliance with the service requirements and conditions detailed in the product literature.

### Two Year Limited Warranty on Installation Tools:

Huck International, Inc. warrants that its installation tools manufactured after 12/1/2016 shall be free from defects in materials and workmanship for a period of two years from date of purchase by the end user. This warranty does not cover special order / non-standard products, or part failure due to normal wear, tool abuse or misapplication, or user non-compliance with the service requirements and conditions detailed in the product literature.

### 90 Day Limited Warranty on Nose Assemblies and Accessories:

Huck International, Inc. warrants that its nose assemblies and accessories shall be free from defects in materials and workmanship for a period of 90 days from date of purchase by the end user. This warranty does not cover special clearance noses, or special order / non-standard product, or part failure due to normal wear, abuse or misapplication, or user non-compliance with the service requirements and conditions detailed in the product literature.

**Useful lifetime** is defined as the period over which the product is expected to last physically, up to the point when replacement is required due to either normal in-service wear, or as part of a complete overhaul. Determination is made on a case-by case basis upon return of parts to Huck International, Inc. for evaluation.

### Tooling, Part(s) and Other Items not manufactured by Huck:

HUCK makes no warranty with respect to the tooling, part(s), or other items manufactured by third parties. HUCK expressly disclaims any warranty expressed or implied, as to the condition, design, operation, merchantability, or fitness for use of any tool, part(s), or other items thereof not manufactured by HUCK. HUCK shall not be liable for any loss or damage, directly or indirectly, arising from the use of such tooling, part(s), or other items or breach of warranty or for any claim for incidental or consequential damages.

Huck shall not be liable for any loss or damage resulting from delays or non-fulfillment of orders owing to strikes, fires, accidents, transportation companies or for any reason or reasons beyond the control of the Huck or its suppliers.

### Huck Installation Equipment:

Huck International, Inc. reserves the right to make changes in specifications and design and to discontinue models without notice.

Huck Installation Equipment should be serviced by trained service technicians only.

Always give the serial number of the equipment when corresponding or ordering service parts.

Complete repair facilities are maintained by Huck International, Inc. Please contact one of the offices listed below.

#### Eastern

One Corporate Drive Kingston, New York 12401-0250  
Telephone (845) 331-7300 FAX (845) 334-7333

#### Outside USA and Canada

Contact your nearest Huck International location (see reverse).

In addition to the above repair facilities, there are Authorized Tool Service Centers (ATSC's) located throughout the United States. These service centers offer repair services, spare parts, Service Parts Kits, Service Tool Kits and Nose Assemblies. Please contact your Huck Representative or the nearest Huck International location (see reverse) for the ATSC in your area.

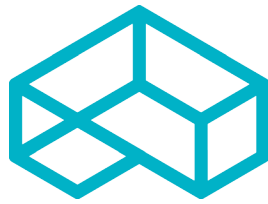

# ARCONIC

Innovation, engineered.

Arconic Inc. (NYSE: ARNC) creates breakthrough products that shape industries. Working in close partnership with our customers, we solve complex engineering challenges to transform the way we fly, drive, build and power.

Through the ingenuity of our people and cutting-edge advanced manufacturing, we deliver these products at a quality and efficiency that ensures customer success and shareholder value.

## Arconic Fastening Systems and Rings world-wide locations:

### AMERICAS

#### Kingston Operations

1 Corporate Drive  
Kingston, NY 12401  
800-278-4825  
845-331-7300  
FAX: 845-334-7333

#### Tucson Operations

3724 East Columbia  
Tucson, AZ 85714  
800-234-4825  
520-747-9898  
FAX: 520-748-2142

#### Carson Operations

900 Watson Center Rd.  
Carson, CA 90745  
800-421-1459  
310-830-8200  
FAX: 310-830-1436

#### Acuña Operations

Hidalgo #120  
Parque Industrial Amistad  
26220 Acuña Coahuila  
Mexico  
FAX: 525-515-1776  
TELEX: 1173530 LUKSME

#### Waco Operations

PO Box 8117  
8001 Imperial Drive  
Waco, TX 76714-8117  
800-388-4825  
254-776-2000  
FAX: 254-751-5259

### EUROPE

#### Telford Operations

Unit C, Stafford Park 7  
Telford, Shropshire  
England TF3 3BQ  
01952-290011  
FAX: 0952-290459

#### Us Operations

BP4  
Clos D'Asseville  
95450 Us par Vigny  
France  
33-1-30-27-9500  
FAX: 33-1-34-66-0600

### AUSTRALIA

#### Melbourne Operations

11508 Centre Road  
Clayton, Victoria  
Australia 3168  
03-764-5500  
Toll Free: 008-335-030  
FAX: 03-764-5510

Huck is Forever, For the Long Haul, The Future of Fastening Technology, The Future of Assembly Technology, The Future of Tooling Technology, and Tools of Productivity are service marks of Huck International. Huck provides technical assistance regarding the use and application of Huck fasteners and tooling.

NOTICE: The information contained in this publication is only for general guidance with

regard to properties of the products shown and/or the means for selecting such products, and is not intended to create any warranty, express, implied, or statutory; all warranties are contained only in Huck's written quotations, acknowledgments, and/or purchase orders. It is recommended that the user secure specific, up-to-date data and information regarding each application and/or use of such products.



**HUCK IS FOREVER.™**